



<b>BUILDING A PNEUMATIC CIRCUIT</b>	<b>262 - 263</b>
<b>3-WAY SERIES VALVES</b>	<b>264 - 273</b>
<b>4-WAY SERIES VALVES</b>	<b>274 - 286</b>
<b>SPECIALTY MODULAR VALVES</b>	<b>287 - 291</b>
<b>APPLICATIONS</b>	<b>295 - 302</b>
<b>PNEUMATIC CIRCUIT BOARDS</b>	<b>303 - 322</b>



One of the major elements of Clippard's award winning design concept is the manifold body. It encircles a central valve cavity with air passages that can be used at any point along the axis of the valve. These passages terminate at the base of the body in a circular octoport pattern. The body mates with a manifold subplate which mounts the complete module and provides 10-32 tapped holes for standard hose fittings. A single molded Octoport gasket, held in place by the two mounting screws, insures a positive seal. Because of the easy availability of an air connection wherever it is required, the manifold body permits valve elements to be designed for maximum performance without the restrictive limitations of rigid port configurations. It also allows multiple porting... using two or more ports as an inlet, outlet, supply, etc. This reduces the amount of external piping needed to complete the circuit. Furthermore the manifold body enables the internal interconnection of ports. This is especially valuable in a number of modules that contain more than one valve.

The separate elements are interconnected in the same module to provide complete subcircuits such as three input "OR", three input "AND", or a two input "NOR". These functions further reduce external piping.



# MODULAR VALVE SYSTEM

## MANIFOLD BODY

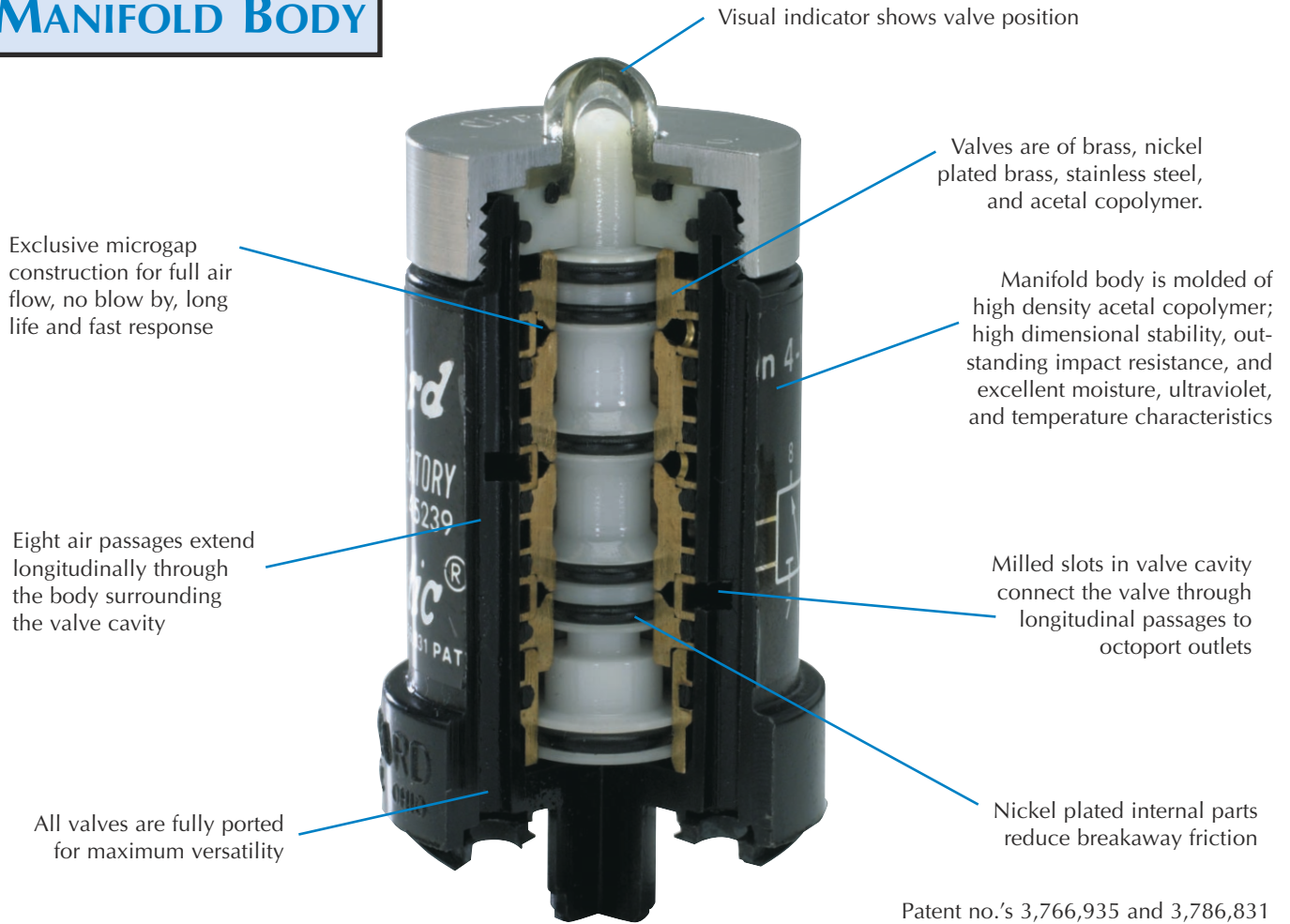

## Octoport Port Coding

The coding method shown here is used on the individual product catalog sheets. You will find a port usage diagram furnished for each variation of each model shown. Letters are used to identify port usage:

- S - Supply or Signal
- O - Output
- E - Exhaust
- P - Pilot Input

Where more than one supply, output, exhaust, etc. are involved in one module, subscript numerals are provided: S<sub>1</sub>, S<sub>2</sub>, etc. Where an auxiliary output is provided it may be identified by the letter O in parentheses: (O).

NOTE: Many of the Octoport valves have multiple ported supplies, outputs, or exhausts, etc. The port usage symbols will usually show one or the other of these ports with an "X" (must be plugged) in it. Both or either of the multiple ports may be used. Unused multiple ports must be plugged. The ANSI symbol will always show which valves have multiple ports.

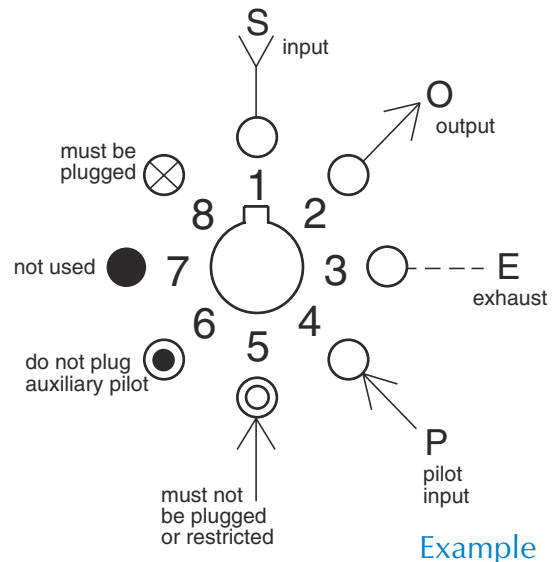

## Base Valve



- Can be used as a:
- 2-way normally closed valve
  - 2-way normally open valve
  - 3-way normally closed valve
  - 3-way normally open valve
  - 3-way diverter valve
  - 3-way selector valve



- Can be used as a:
- 4-way fully ported valve
  - Dual 2-way valves (one N.O. & one N.C.)
  - Dual 3-way valves with common exhaust (one N.O. & one N.C.)

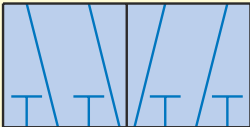

- Can be used as a:
- 6-way fully ported valve
  - Dual 2-way normally closed valve
  - Dual 2-way normally open valve
  - Dual 3-way normally closed valve
  - Dual 3-way normally open valve
  - Dual selector valve

Versatility is the key when it comes to Clippard's Minimatic® Modular Valves. Available in an unlimited variety of directional, flow, pressure and special control valves - each in a valve body designed to mount and link together with a simple piping system. The piping system eases assembly and plumbing, resulting in reduced labor costs, errors in installation, and the potential for plumbing leakage. In addition, multiple valve elements can be contained in a single body; providing incredible flexibility and variety to accomplish a myriad of control challenges. The Minimatic® modular valves are the supreme "Plug and Play" devices for pneumatic applications.

## Actuation Methods

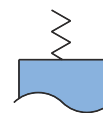

Spring Return

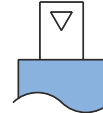

Air Pilot



Spring & Auxiliary Pilot

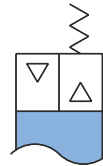

Removable Spring & Auxiliary Pilot

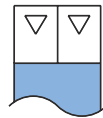

2 Air Pilots "OR"

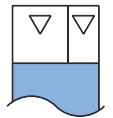

Differential Air Pilots

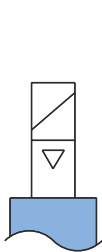

Solenoid Piloted

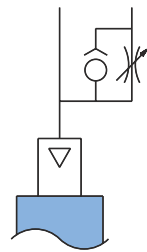

Delay Out From Air Pilot

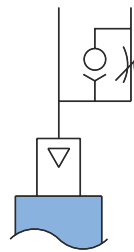

Delay In To Air Pilot

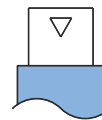

Low Pressure Air Pilot

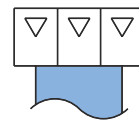

3 Air Pilots "OR"

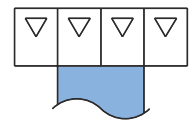

4 Air Pilots "OR"



Independent Shuttle Valve & Air Pilot



Shuttle Valve To Air Pilot



Shuttle Valve To Low Pressure



Delay To Air Pilot



Bleed Pressure Pilot

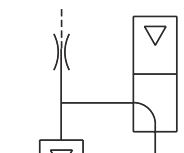

Fluidic Interface Pilot



# MODULAR VALVE SYSTEM

## SIMPLIFIED ASSEMBLY

Screws and lockwashers (replacement part R-105) plated steel, binder head, 10-32 thread.



Molded gasket (replacement part R-104) furnished with each module.

Custom plastic manifold subplates of clear plastic have most interconnections inside; speed assembly, assure integrity of circuit. Valves plug in easily.

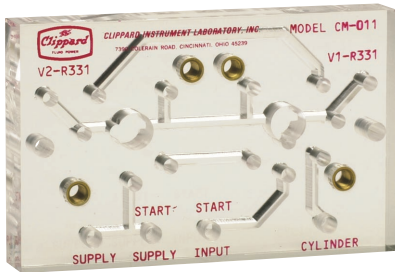

Standard mounting strips attach to interlocked subplates with 10-32 screws. Resulting circuit plate is rigid and strong. Modules plug in to circuit plate and are held by two fully captivated screws. Molded gasket provides seal between each module and subplate.

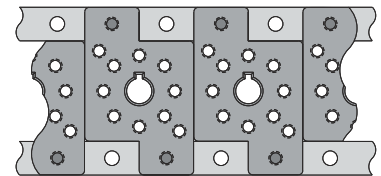
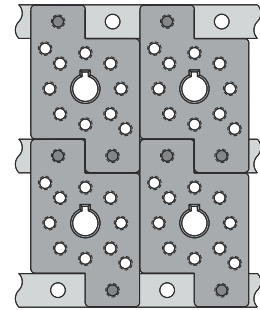
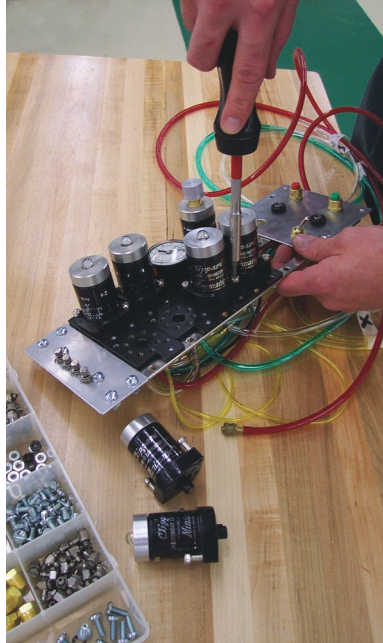

See page 262 for further details.

## Auxiliary Pilots

One of the bonus features of the Clippard Minimatic® modular components system is the availability and use of auxiliary pilots. These auxiliary pilots are included as standard on the following valves:

R-301	R-311	R-321	R-323	R-331	R-333
R-341	R-343	R-401	R-431	R-443	R-445
R-453	R-461	R-471	R-481		

All of these valves are air piloted with a spring return, with the added advantage of an auxiliary air pilot on the spring side of the valve. The auxiliary pilot consists of an air pilot in addition to the standard spring pilot. This feature greatly increases the versatility of the valve.

The auxiliary pilot may be used to cancel the force of the opposite pilot, thus enabling the spring to shift the valve, even though there is still air pressure on the opposite pilot. (Except R-431)

The majority of these valves will be used without the auxiliary pilot, but the ANSI symbols and port usage drawings show the auxiliary pilot.

## Octoport Stamp

Part number R-108

Complete pneumatic circuit drawings in minimum time with this small, self inked octoport stamp.



## System Requirements

The Clippard Minimatic® modular components system is designed to operate on standard shop air. The air supply should be reasonably clean and dry for optimum performance. The system operating range is 0 to 150 psi. Recommended filtration is 40 micron. Many units have pilot pressure requirements of 20 to 40 psi, therefore, system pressure should be sufficient to assure 40 psi as the absolute minimum pilot pressure at all times. A normal system operating pressure from 60 to 100 psi should adequately provide this. The system operates in a temperature range of 32° F to 230° F.

NOTE: Constant operation at temperature range extremes may affect system performance.

## Manifold Module Dimensions

Module manifold body is injection molded high density acetal copolymer for high dimensional stability, outstanding impact resistance, and excellent moisture, ultraviolet, and temperature characteristics.

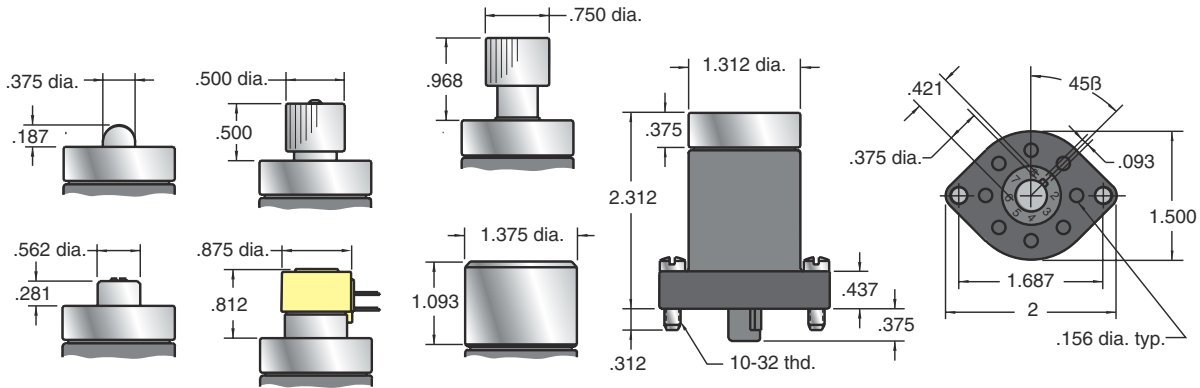

## Subplate Dimensions

R-101 subplate mounts to mounting strips with 10-32 screws and lockwashers provided. Ports on module base are numbered in the same pattern as on the subplate, making piping easy to identify. Module stem is keyed to fit center hole in subplate; assures fast insertion and proper positioning.

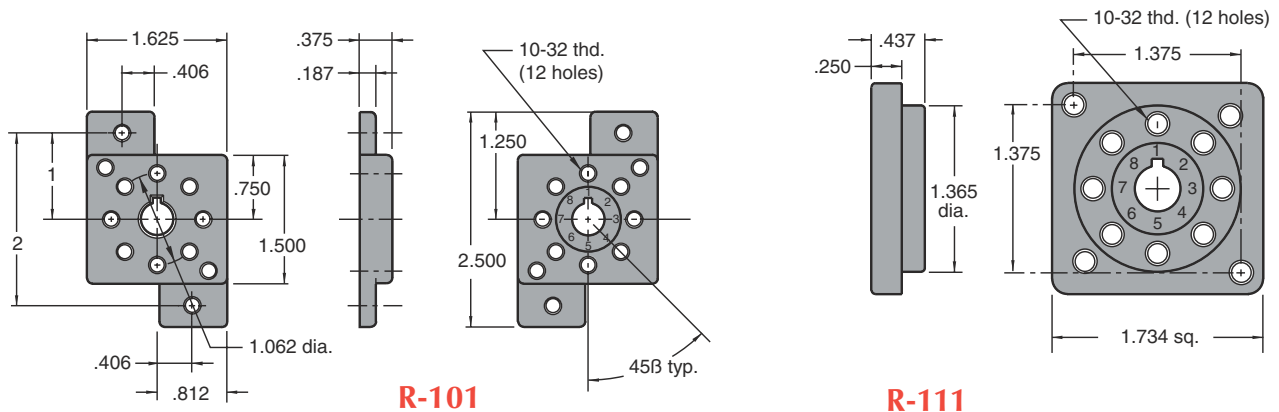

R-111 subplate mounts in 1 3/8" hole in electrical box, control panel. Mounting screws and gasket provided seal subplate to mounting plate.

## Mounting Strips & Stand-Off Dimensions

### R-107-20

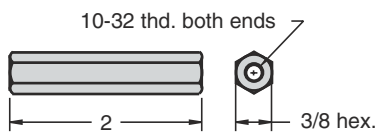

For providing space beneath assembled group of modules, use R-106 (order R-107-20, packet of four with hardware). Provides 2" clearance from enclosure wall for piping with Clippard fittings and tubing. Keeps piping and installation neat.

When subplates are mounted to mounting strips, the components build into a strong, rigid assembly. Because of extra tolerance in the holes, note that strips may be adjusted before screws are fully tightened. This permits accurate alignment of subplates. The identifying number following the second dash in the part number indicates the number of modules the strip will accommodate while still proving a short extension with one hole at both ends for using in mounting the assembly to stand-offs or other structures. The strip will accommodate 1 additional module if no extensions for mounting are needed. (Every two holes will accept a subplate.)

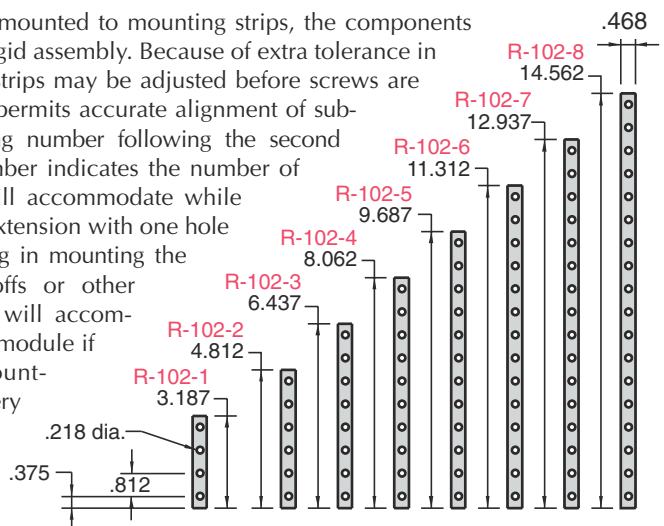

## STEP ONE

### Pneumatic Circuit

The first step in building a modular circuit is designing the pneumatic circuit using ANSI symbols.

Starting on page 291 we have a number of circuits utilizing Clippard Minimatic Modular Components. We have chosen the Two Hand No Tie Down Circuit for this demonstration.

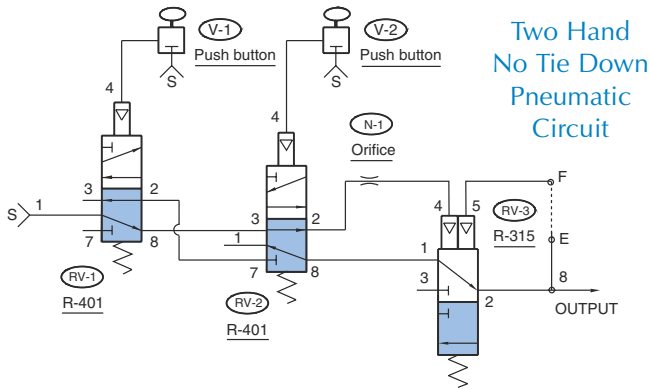

## STEP TWO

### Specifications for the R-315 modular valve

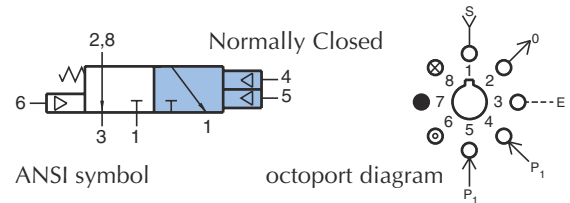

### Octoport Diagrams

The next step is selecting the octoport diagram for each modular valve. Each Clippard modular valve (R-series) has its own unique octoport diagram which is shown to the right of the ANSI symbol.

See page 258 for clues for deciphering the Octoport port coding.

## STEP THREE

### Components for Modular Circuit

Next, you need to gather the required components. Typically, the modular portion of a circuit consists of modular valves, subplates, mounting strips, 1/16" and 1/8" fittings, 1/16" and 1/8" hose, and the main air supply connect fitting.

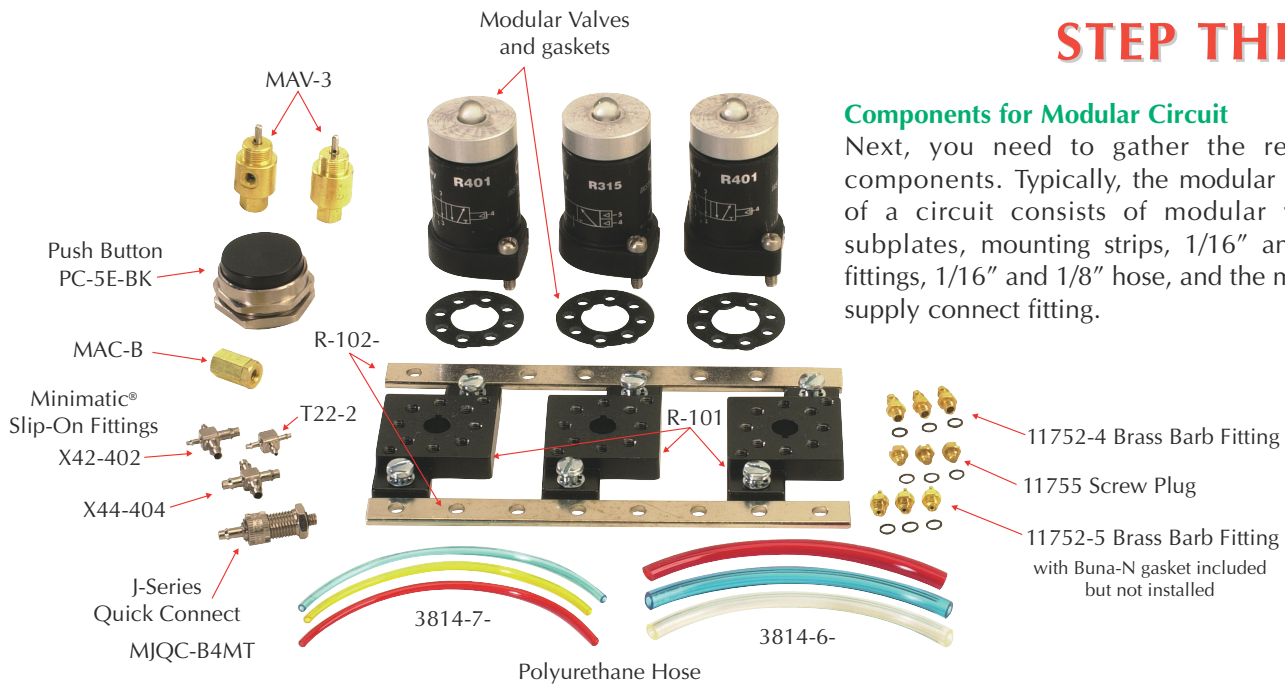

## STEP FOUR

### Mounting Strip and Subplate Assembly

The next step is assembling the mounting strips (R-102-) and subplates (R-101).

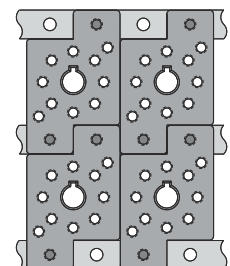
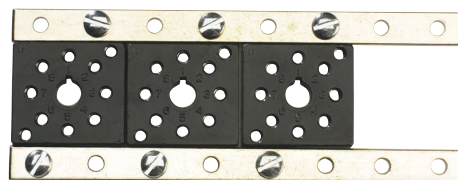

Possible configurations for subplates

## Subplate and Fitting Installation

The next step is to install the fittings into the R-101 subplates using the octoport, octoport port coding, and pneumatic circuit diagrams. Generally, 1/16" hose is used for pilot ports and their adjoining lines and 1/8" hose are for supply lines and cylinders.

Looking at the two hand no tie down circuit:

1. Valve RV-1 has fitting 11752-5 (10-32 to 1/16" ID hose fitting) installed in ports 4 and 8
2. Fitting 1752-4 (10-32 thd. to 1/8" ID hose fitting) installed in ports 1 and 2 because port 1 is the main air supply for the circuit and port 2 is the outlet.
3. On valves V-1 and V-2, fitting 11752-5 was installed in both the inlet and outlet of each valve because both valves are used for pilot actuation of valves RV-1 and RV-2.

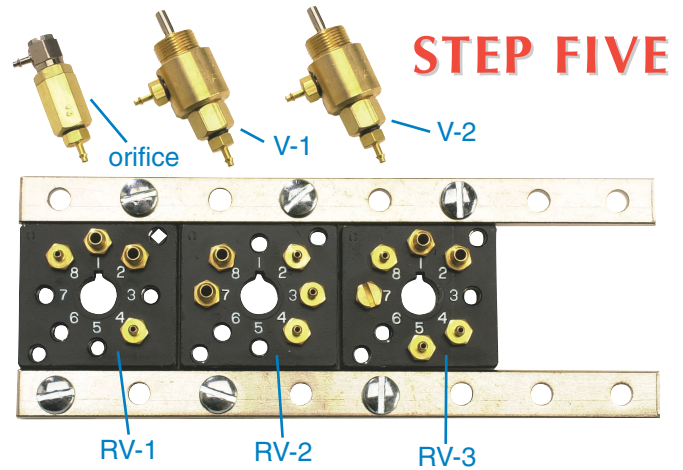

4. Being in a pilot line, the inline fixed orifice air choke N-1 was fitted with an 11752-5 on one end and a UTO-2 universal "L" fitting on the other.

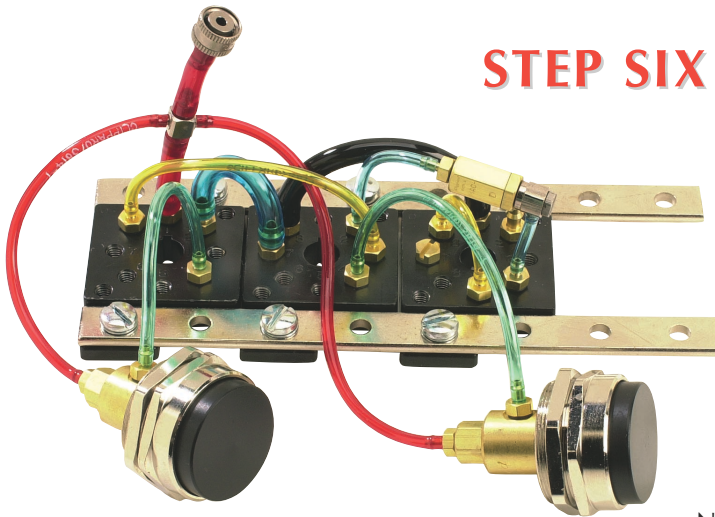

## STEP SIX

### Connecting Hose

With the fittings installed, the circuit is ready for hose. The color coding we use at Clippard is quite simple. Red hose is used for all supply lines. For all other hose as many different colors as possible are used in order to facilitate circuit trouble shooting.

1. Supply lines - Red hose
2. The 1/16" ID fittings require 3814-7- hose
3. The 1/8" ID fittings require 3814-6- hose
4. The main supply line was fitted with a MJQC-CB4 which can be attached to any of the MJQC valve bodies.

Note: The MJQC series is not compatible with the MQC series.

## STEP SEVEN

### Modular Valve Hook-Up

The final assembly step is installing the modular valves and mounting gasket to the subplates.

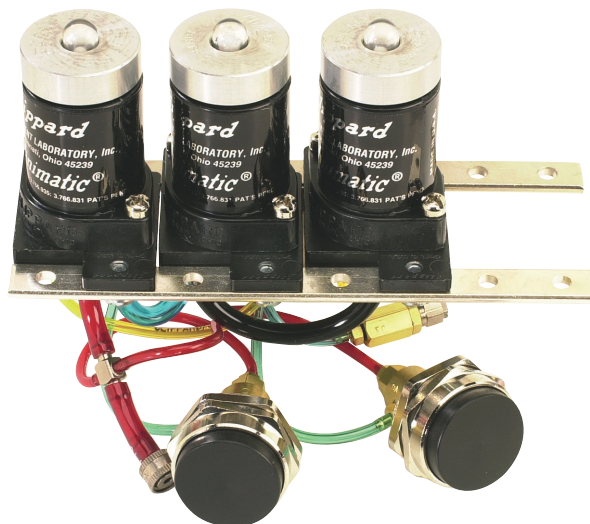

Hose and barb sizes were picked with this particular application in mind. Both may vary to meet your needs. Feel free to contact our facility for technical support.



# MODULAR 3-WAY VALVE

## R-301



Three way valve

**Features:**

- Indicator shows valve in shaded position
- Multiple porting speeds piping
- Micro gap construction - snap action and no blow by
- Balanced design allows speed control at exhausts

**Performance:**

Flow (SCFM @ 100 psi).....	9
Pilot pressure (psi) Minimum.....	40
Temperature.....	32° to 180° F
Working pressure.....	vacuum to 150
Response time (milliseconds).....	10

**Description:**

R-301 is a 3-way, spring return, fully ported, piloted valve. It can be used normally-OPEN, normally-CLOSED, as a diverter or as a selector. It can also be used as a 2-way valve by plugging the exhaust ports.

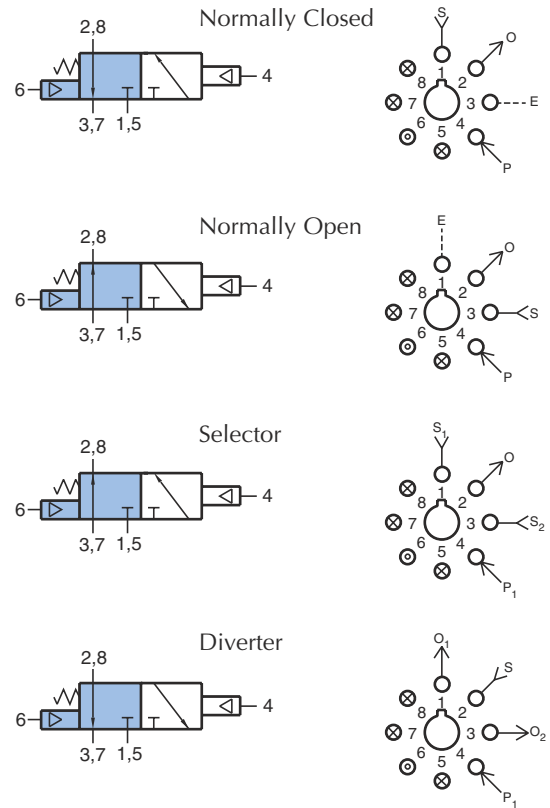

## R-302



Three way valve

**Features:**

- Indicator shows valve in shaded position
- Multiple porting speeds piping
- Micro gap construction - snap action and no blow by
- Balanced design allows speed control at exhausts

**Performance:**

Flow (SCFM @ 100 psi).....	9
Pilot pressure (psi) minimum.....	20
Temperature.....	32° to 180° F
Working pressure.....	0 to 150
Response time (milliseconds).....	10

**Description:**

R-302 is a 2-position, 3-way, double-piloted, fully-ported valve. It can be used normally-OPEN, normally-CLOSED, as a 2-position diverter, as a 2-position selector, or as a 2-way valve by plugging the exhaust ports.

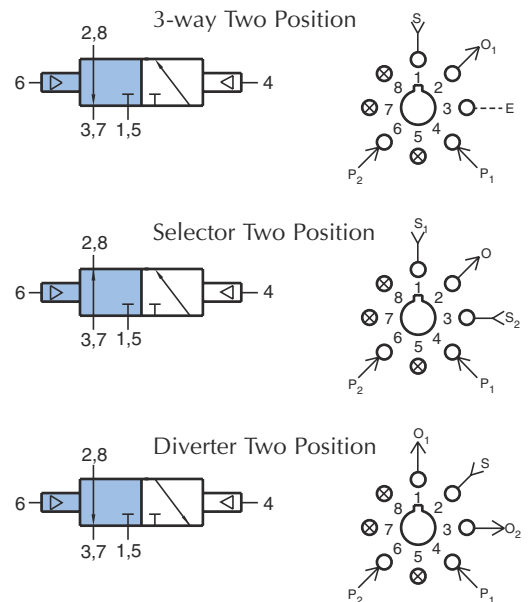



## R-305

Three way low pressure pilot valve



**Features:**

- Pilot actuates valve with low pressure signal
- Multiple porting speeds piping
- Micro gap construction - snap action and no blow by
- Balanced design allows speed control at exhausts

**Performance:**

Flow (SCFM @ 100 psi).....	9
Pilot pressure (psi) minimum.....	10
Temperature.....	32° to 180° F
Working pressure.....	0 to 150
Response time (milliseconds).....	10

**Description:**

R-305 is a 3-way, spring-return, fully ported valve with a low pressure pilot. Pilot pressure signals as low as 10 psi will actuate the valve. The valve can be used normally-OPEN, normally-CLOSED, as a selector or as a diverter. The R-305 may be used in place of an R-301 valve where a lower pilot actuation pressure is desired. It can also be used as a 2-way valve by plugging the exhaust ports.

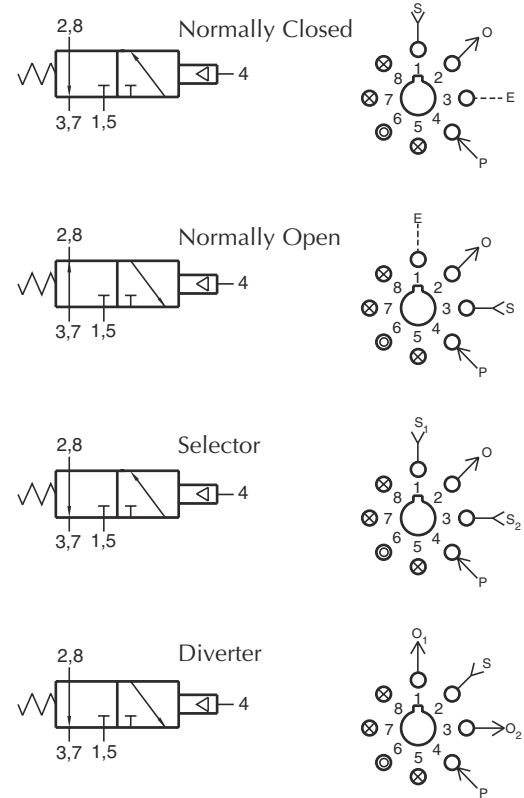

## R-310

Three way reset valve



**Features:**

- Indicator shows valve in shaded position
- Multiple porting speeds piping
- Micro gap construction - snap action and no blow by
- Balanced design allows speed control at exhausts
- Unique piloted spring reset

**Performance:**

Flow (SCFM @ 100 psi).....	9
Pilot pressure (psi) minimum (against spring).....	40
Pilot pressure (psi) minimum (spring retracted).....	20
Temperature.....	32° to 180° F
Working pressure.....	0 to 150
Response time (milliseconds).....	10

**Description:**

R-310 is a 3-way, fully ported valve with a special air retracted spring return that will return the valve to a definite position when there is no signal at ports 5 and 4. This "reset" feature may be used in circuits in the event of loss of air pressure or to change the operating characteristics of the valve in the circuit in response to an independent input at port 5. When port 5 is not piloted, the R-310 acts as an R-301 3-way spring return, fully ported valve. When port 5 is actuated, the R-310 acts as an R-302 3-way, two position valve. With no signal at port 5, a signal at port 6 acts as an auxiliary pilot type valve and will override a signal at port 4.

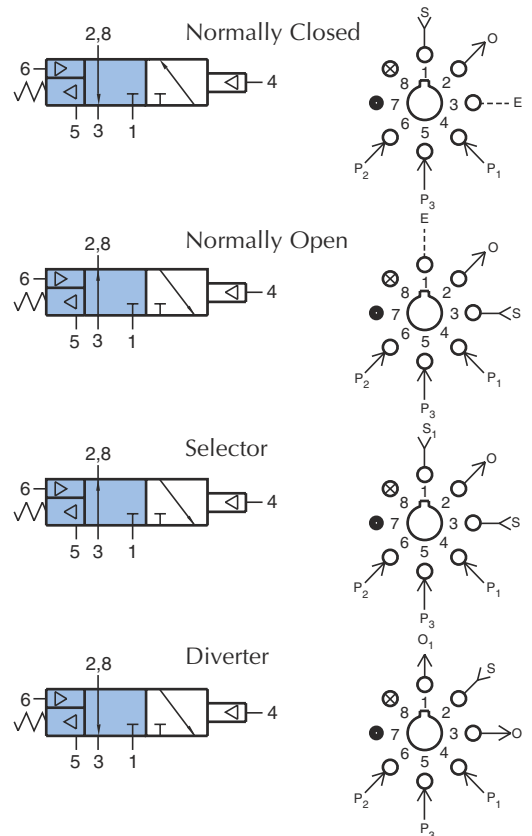

## R-311



### Description:

R-311 is a 3-way, spring return, fully ported valve with four pilots. Any one of the four pilots will actuate the valve. Actuating more than one pilot has no additional effect. Pilot signals must be absent at all four pilots to release the valve. The valve can be used normally - OPEN, normally - CLOSED, as a selector or as a diverter, all with four pilot inputs. It can also be used as a 2-way valve by plugging the exhaust ports. The R-311 may be used to replace an R-301 or R-321 valve in a circuit when additional pilot inputs are required. The R-311 also features an auxiliary pilot on the spring side of the valve. The auxiliary pilot will overcome any one or all of the four input pilots.

### Three way multiple pilot valve

#### Features:

- Indicator shows valve in shaded position
- Multiple pilots reduces number of valves - reduces piping and space required
- Micro gap construction - snap action and no blow by
- Balanced design allows speed control at exhaust

#### Performance:

Flow (SCFM @ 100 psi).....9  
 Pilot pressure (psi) minimum.....40  
 Temperature.....32° to 180° F  
 Working pressure.....0 to 150  
 Response time (milliseconds).....10

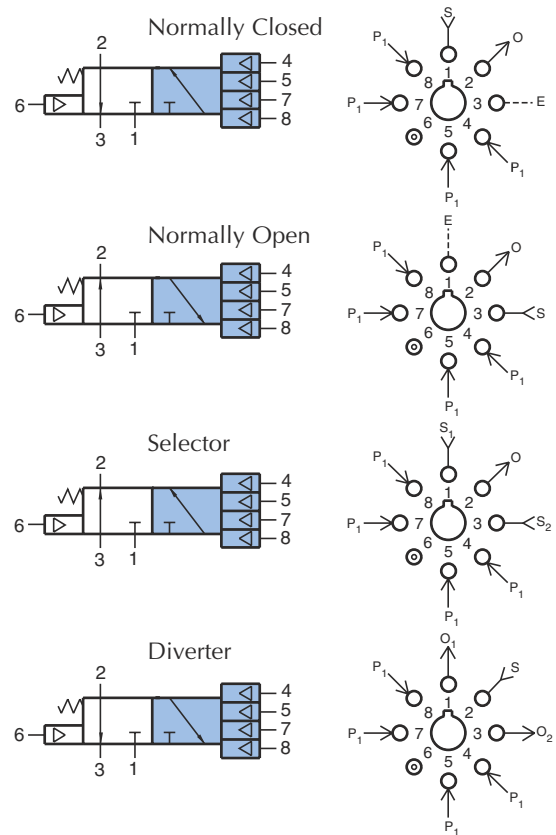

## R-312



### Description:

R-312 is a 3-way, two position, fully ported valve with four pilots on one position. Any one of the four pilots on one position will actuate the valve. Actuating more than one pilot has no additional effect. Pilot signals must be absent at all four pilots before the opposite pilot can shift the valve. The valve can be used normally-OPEN, normally-CLOSED, as a selector, or as a diverter, all with four pilot inputs. It can also be used as a 2-way valve by plugging the exhaust ports. The R-312 may be used to replace an R-302 or R-322 valve in a circuit when additional pilot inputs are required.

### Three way multiple pilot valve

#### Features:

- Indicator shows valve in shaded position
- Multiple pilots reduces number of valves - reduces piping and space required
- Micro gap construction - snap action and no blow by
- Balanced design allows speed control at exhaust

#### Performance:

Flow (SCFM @ 100 psi).....9  
 Pilot Pressure (psi) minimum.....20  
 Temperature.....32° to 180° F  
 Working pressure.....0 to 150  
 Response time (milliseconds).....10

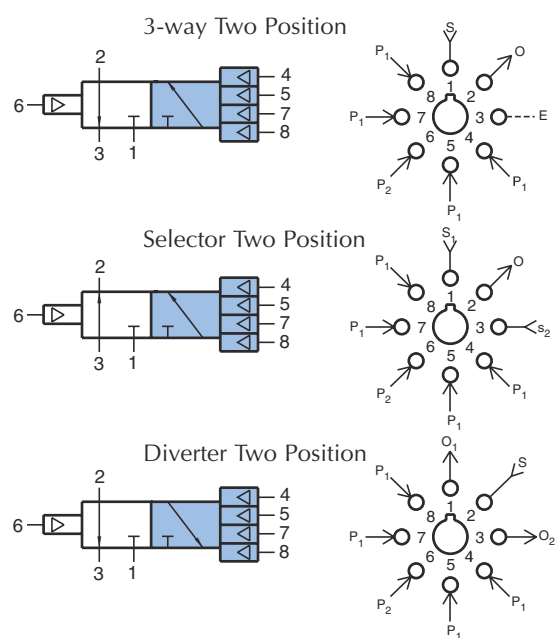

## R-314



Three way multiple pilot valve

**Features:**

- Multiple pilots reduces number of valves - reduces piping and space required
- Micro gap construction - snap action and no blow by
- Balanced design allows speed control at exhausts

**Performance:**

Flow (SCFM @ 100 psi).....	9
Pilot pressure (psi) minimum.....	20
Temperature.....	32° to 180° F
Working pressure.....	0 to 150
Response time (milliseconds).....	10

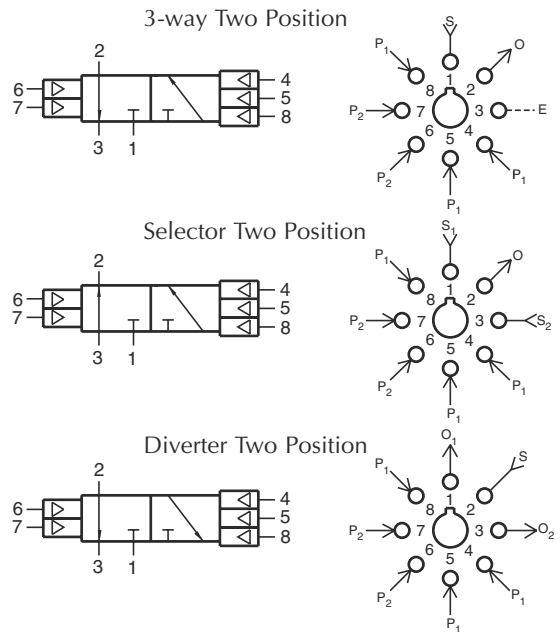

**Description:**

R-314 is a 3-way, air piloted, two position valve. It has three pilots on one side and two pilots on the other side. (see symbol) Actuating more than one pilot on the same side has no additional effect. Pilot signals must be absent from all pilots (on the same side) before an opposite pilot will shift the valve. The valve can be used normally-OPEN, normally-CLOSED; as a selector, or as a diverter. It may be used as a 2-way valve by plugging the exhaust ports.

## R-315



Three way multiple pilot valve

**Features:**

- Indicator shows valve in shaded position
- Multiple pilots reduces number of valves - reduces piping and space required
- Micro gap construction - snap action and no blow by
- Balanced design allows speed control at exhaust

**Performance:**

Flow (SCFM @ 100 psi).....	9
Pilot pressure (psi) Minimum.....	40
Temperature.....	32° to 180° F
Working pressure.....	0 to 150
Response time (milliseconds).....	10

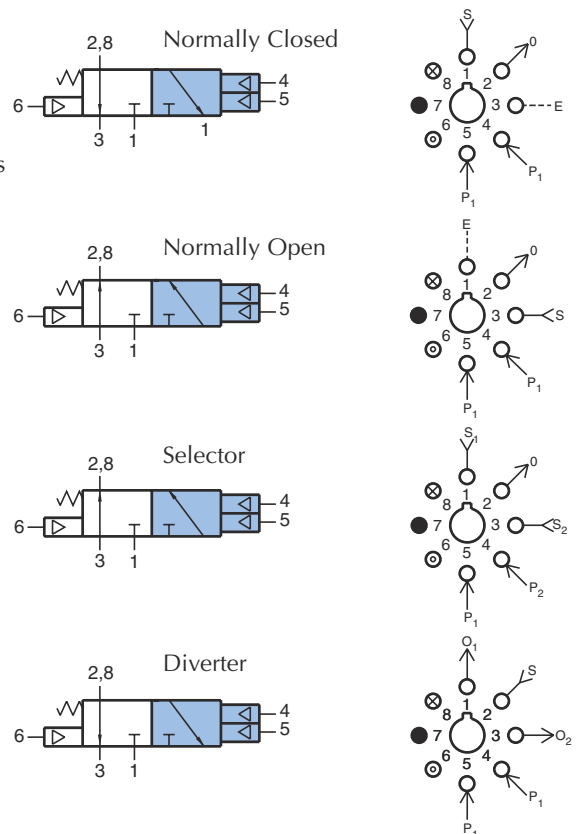

**Description:**

R-315 is a 3-way, spring return, fully ported valve with two independent pilots that make it ideal for "latch" circuits. Either of the two pilots will actuate the valve. Actuating more than one pilot has no additional effect. Pilot signals must be absent at both pilots to release the valve. The valve can be used normally-OPEN, normally-CLOSED, as a selector or as a diverter. It can also be used as a 2-way valve by plugging the exhaust ports. The R-315 may be used to replace an R-301 valve in a circuit when additional pilot inputs are required. The R-301 also features an auxiliary pilot on the spring side of the valve. The auxiliary pilot will overcome any one or all of the four input pilots.



# MODULAR 3-WAY COMBINATION VALVES

## R-321



Three way combination valve

**Features:**

- Indicator shows valve in shaded position
- Multiple porting speeds piping
- Micro gap construction - snap action and no blow by
- Balanced design allows speed control at exhausts

**Performance:**

Flow (SCFM @ 100 psi).....9  
 Pilot pressure (psi) minimum.....40  
 Temperature.....32° to 180° F  
 Working pressure.....0 to 150  
 Response time (milliseconds).....10

**Description:**

R-321 is a 3-way, spring return, fully ported valve with an interconnected shuttle valve in one pilot line to provide two inputs to the pilot. It can be used normally - OPEN, normally - CLOSED, as a diverter, or as a selector. Auxiliary outlet is provided through port 7, which should be plugged if not used.

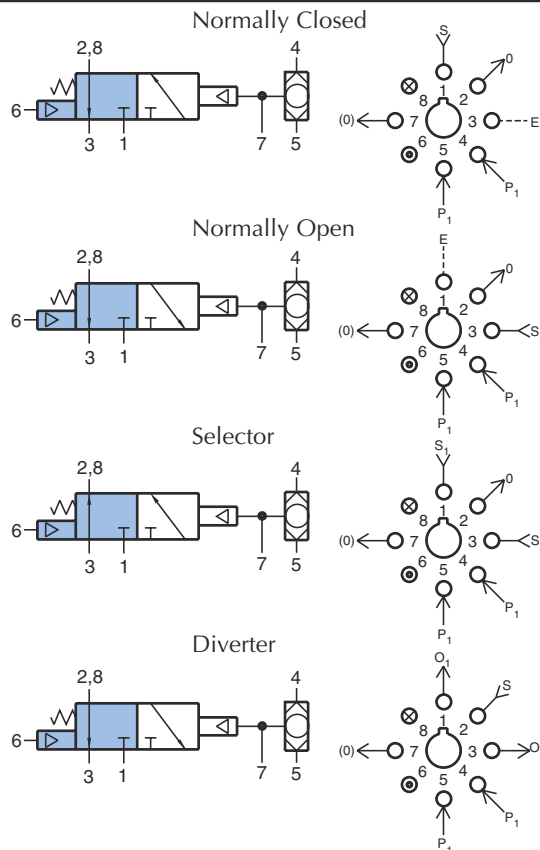

## R-322



Three way combination valve

**Features:**

- Indicator shows valve in shaded position
- Multiple porting speeds piping
- Micro gap construction - snap action and no blow by
- Balanced design allows speed control at exhausts

**Performance:**

Flow (SCFM @ 100 psi).....9  
 Pilot pressure (psi) minimum.....20  
 Temperature.....32° to 180° F  
 Working pressure.....0 to 150  
 Response time (milliseconds).....10

**Description:**

R-322 is a 3-way valve, 2-position, fully ported, with an interconnected shuttle valve in one pilot line to provide two inputs to the pilot. It can be normally-OPEN, normally-CLOSED, as a 2-position selector, or as a 2-position diverter. Auxiliary outlet is provided through port 7, which should be plugged if not used.

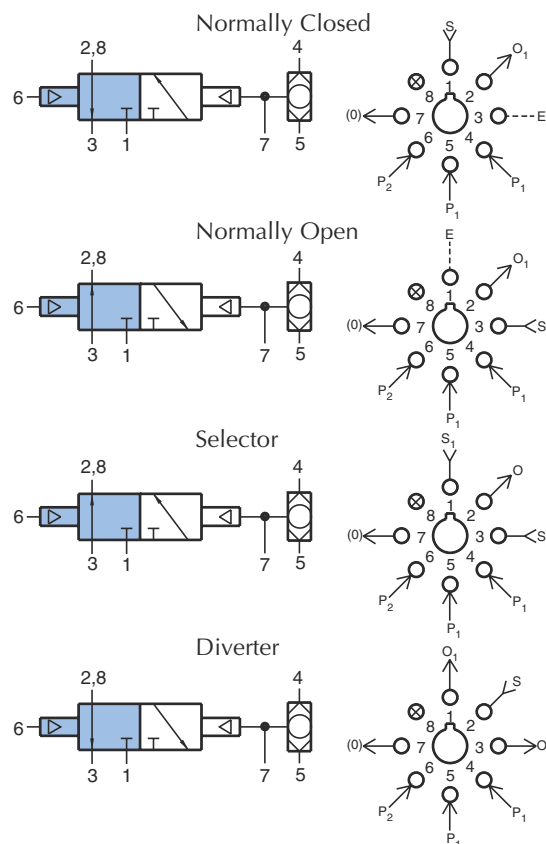

## R-323



Three way combination valve

**Features:**

- Indicator shows valve in shaded position
- Multiple valves save space
- Micro gap construction - snap action and no blow by
- Balanced design allows speed control at exhausts

**Performance:**

Flow (SCFM @ 100 psi).....	9
Pilot pressure (psi) minimum.....	40
Temperature.....	32° to 180° F
Working pressure.....	0 to 150
Response time (milliseconds).....	10

**Description:**

R-323 is a 3-way, spring return, fully ported valve with an independent shuttle valve in the same body. Both valves may be used independently in a circuit. The 3-way can be used normally-OPEN, normally-CLOSED; as a diverter, or as a selector. The R-323 also features an auxiliary pilot on the spring side of the valve.

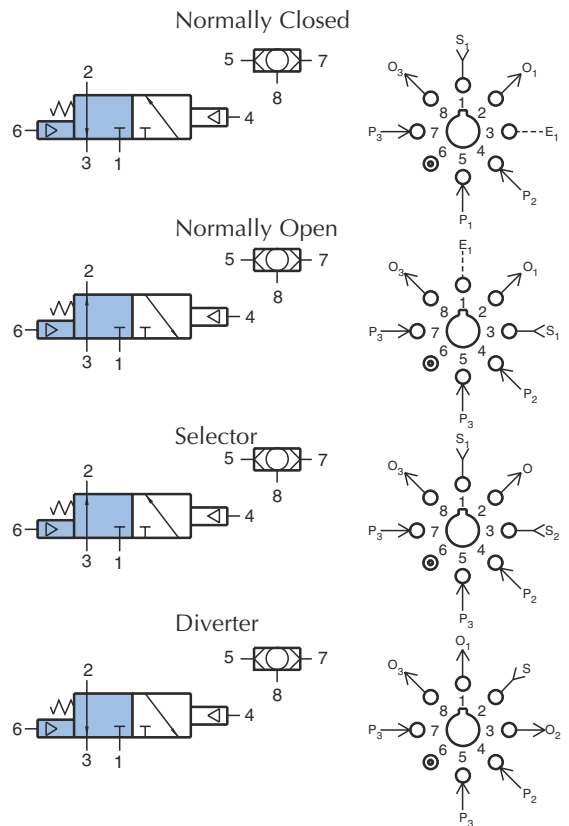

## R-324



Three way combination valve

**Features:**

- Indicator shows valve in shaded position
- Multiple valves save space
- Micro gap construction - snap action and no blow by
- Balanced design allows speed control at exhausts

**Performance:**

Flow (SCFM @ 100 psi).....	9
Pilot pressure (psi) minimum.....	20
Temperature.....	32° to 180° F
Working pressure.....	0 to 150
Response time (milliseconds).....	10

**Description:**

R-324 is a 3-way, two position, fully ported valve with an independent shuttle valve in the same body. Both valves may be used independently in a circuit. The 3-way can be used normally-OPEN, normally-CLOSED; as a diverter, or as a selector.

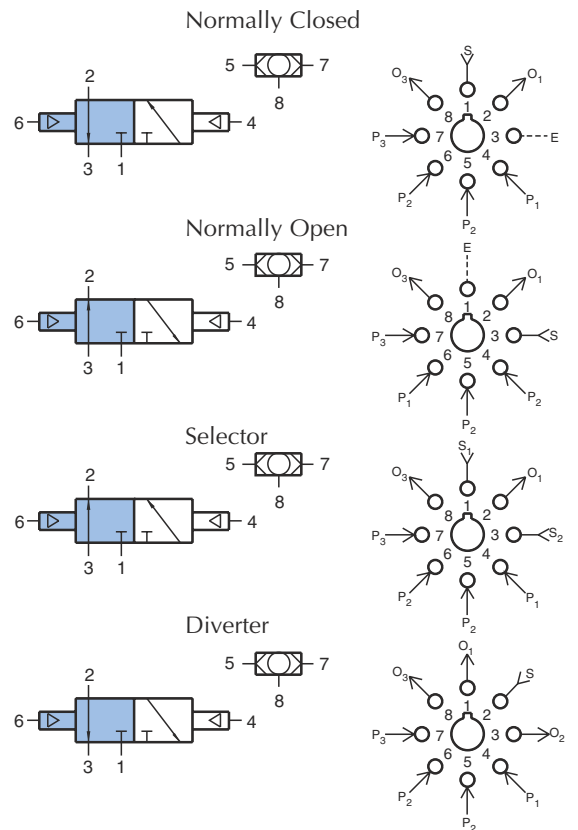



# MODULAR 3-WAY COMBINATION VALVES

## R-325



Three way low pressure combination valve

**Features:**

- Pilot actuates valve with low pressure signal
- Multiple porting speeds piping
- Micro gap construction - snap action and no blow by
- Balanced design allows speed control at exhausts

**Performance:**

Flow (SCFM @ 100 psi).....9  
 Pilot pressure (psi) minimum.....10  
 Temperature.....32° to 180° F  
 Working pressure.....0 to 150  
 Response time (milliseconds).....10

**Description:**

R-325 is a 3-way, spring return, fully ported valve with a low pressure pilot and an interconnected shuttle valve to provide two inputs to the low pressure pilot. It can be used normally - CLOSED, normally - OPEN, as a 2-position diverter, or as a 2-position selector. The R-325 may be used in place of an R-321 valve where a lower pilot pressure is desired. Auxiliary outlet is provided through port 7, which should be plugged if not used.

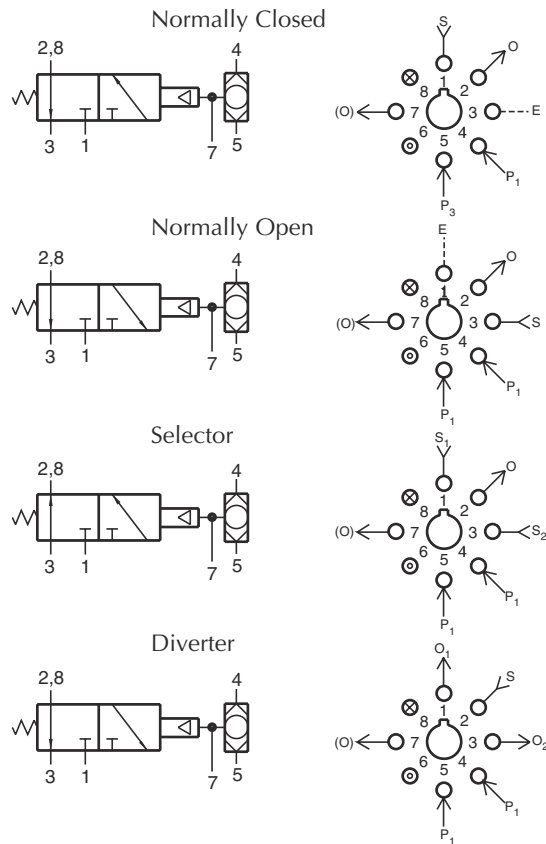

## R-331 R-333



Three way delay valve

**Features:**

- Multiple porting speeds piping
- Micro gap construction - snap action and no blow by
- Screwdriver slot needle adjustment deters tampering (R-333)
- Knurled knob for fast accurate adjustments - no tools needed (R-331)
- 0-5 seconds range

**Performance:**

Flow (SCFM @ 100 psi).....9  
 Pilot pressure (psi) Minimum.....40  
 Temperature.....32° to 180° F  
 Working pressure.....0 to 150  
 Response time (milliseconds).....10

**Description:**

R-331 and R-333 are dual element combinations consisting of a fully ported, spring return, 3-way valve, and an adjustable flow control to provide a delay "IN" function. Input signal at port 4 will be delayed through adjustable flow control and will delay the actuation of the valve. The 3-way valve is fully ported and can be used normally-OPEN, normally-CLOSED, or as a selector or diverter. Port 7 is an auxiliary for adding volume for longer time delays. If not used, port 7 should be plugged.

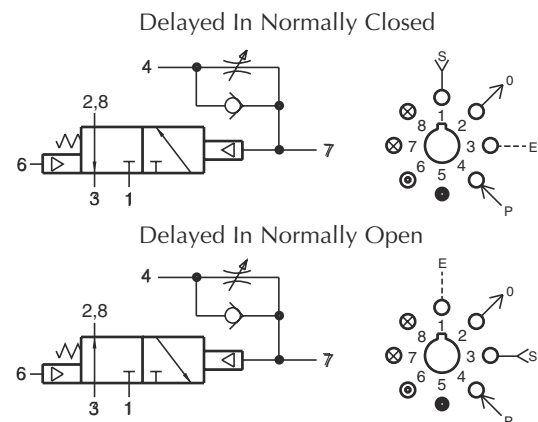

## R-332 R-334



### Three way delay valve

#### Features:

- Multiple porting speeds piping
- Micro gap construction - snap action and no blow by
- Screwdriver slot needle adjustment deters tampering (R-334)
- Knurled knob for fast accurate adjustments - no tools needed (R-332)
- 0-3 seconds range

#### Performance:

Flow (SCFM @ 100 psi).....	9
Pilot pressure (psi) minimum.....	20
Temperature.....	32° to 180° F
Working pressure.....	0 to 150
Response time (milliseconds).....	10

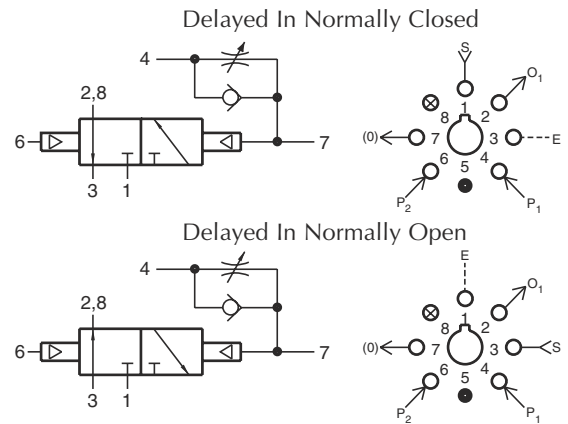

#### Description:

R-332 and R-334 are dual element combinations consisting of a 2-position, 3-way valve, fully ported, and an adjustable flow control to provide a delay "IN" function. Input signal at port 4 will be delayed through adjustable flow control and will delay the actuation of the valve. The 3-way valve can be used normally-OPEN, normally-CLOSED, as a 2-position selector or 2-position diverter. Port 7 is an auxiliary for adding volume for longer time delays. If not used, port 7 should be plugged.

## R-341 R-343



### Three way delay valve

#### Features:

- Multiple porting speeds piping
- Micro gap construction - snap action and no blow by
- Screwdriver slot needle adjustment deters tampering (R-343)
- Knurled knob for fast accurate adjustments - no tools needed (R-341)
- 0-7 seconds range

#### Performance:

Flow (SCFM @ 100 psi).....	9
Pilot pressure (psi) minimum.....	40
Temperature.....	32° to 180° F
Working pressure.....	0 to 150
Response time (milliseconds).....	10

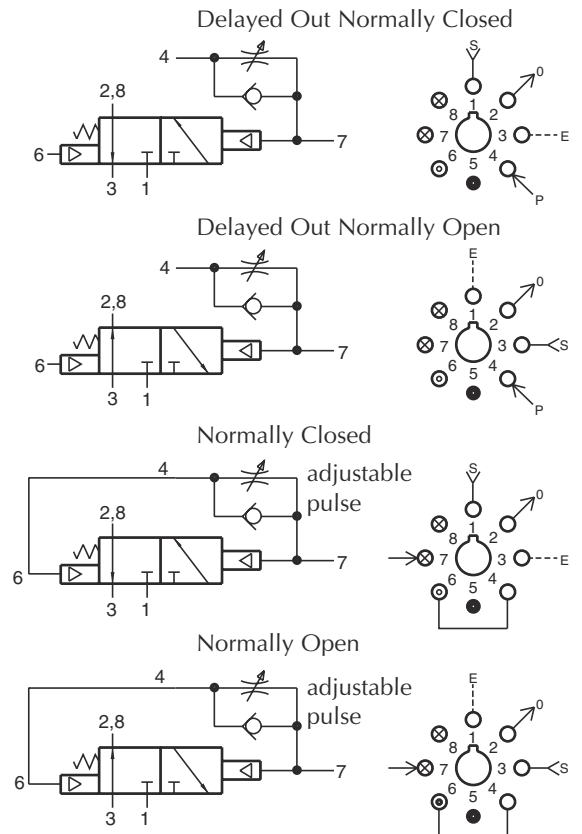

#### Description:

R-341 and R-343 are dual element combinations consisting of a fully ported spring return, 3-way valve and an adjustable flow control to provide a delay "out" function. Input signal at port 4 actuates the valve immediately; and upon loss of pressure signal at port 4, the valve remains in position until pilot pressure decays through the flow control. The valve can be used as normally - OPEN or normally-CLOSED, and as a diverter or selector. Port 7 is an auxiliary for adding volume for longer time delays. If not used, port 7 should be plugged.



# MODULAR MULTIPLE 3-WAY VALVES

## R-351

Dual normally closed three way valve

**Features:**

- Micro gap construction - snap action and no blow by
- Two independent valves in one module
- Saves space

**Performance:**

Flow (SCFM @ 100 psi).....9  
 Pilot pPressure (psi) minimum.....40  
 Temperature.....32 to 180° F  
 Working pressure.....0 to 150  
 Response time (milliseconds).....10

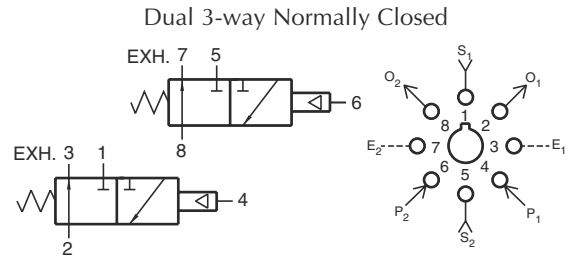

**Description:**

R-351 is a dual element combination of 2 independent, spring return, 3-way valves in a single manifold, set-up for normally-CLOSED usage only. Ports 3 and 7 are exhausts to atmosphere and cannot be restricted.

## R-352

Dual three way valve

**Features:**

- Micro gap construction - snap action and no blow by
- Two independent units in one module
- Common supply eliminates extra piping

**Performance:**

Flow (SCFM @ 100 psi).....9  
 Pilot pressure (psi) minimum.....40  
 Temperature.....32° to 180° F  
 Working pressure.....0 to 150  
 Response time (milliseconds).....10

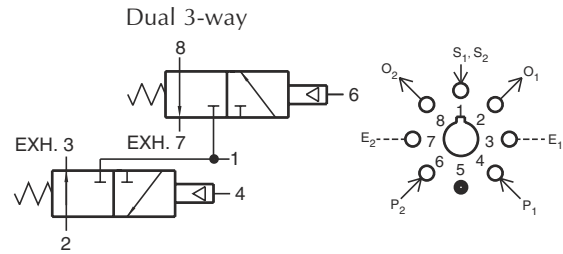

**Description:**

R-352 is a dual element combination consisting of 2 independent, spring return, 3-way normally closed valves with a common inlet. Ports 3 and 7 are exhausts to atmosphere, and can not be restricted.



## R-353



Dual three way valve

**Features:**

- Micro gap construction - snap action and no blow by
- Complete function in one module
- Auxiliary outputs save fittings and time

**Performance:**

Flow (SCFM @ 100 psi).....	9
Pilot pressure (psi) minimum.....	40
Temperature.....	32° to 180° F
Working pressure.....	0 to 150
Response time (milliseconds).....	10

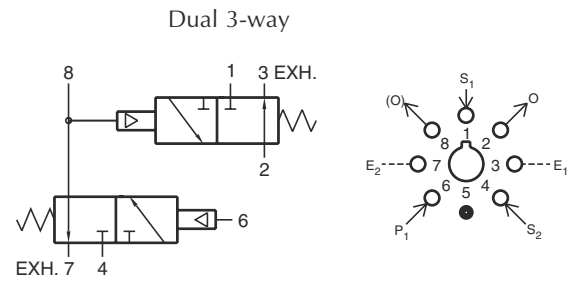

**Description:**

R-353 is a dual element combination consisting of 2 normally-CLOSED, spring return, 3-way valves interconnected to form a 3-input "AND" subcircuit. Ports 3 and 7 are exhausted to atmosphere, and should not be restricted. Ports 1, 4, and 6 are inputs. Port 2 is output. Port 8 is an auxiliary output and should be plugged if not used.

## R-355



Dual normally open three way valve

**Features:**

- Micro gap construction - snap action and no blow by
- Two independent units in one module
- Saves space

**Performance:**

Flow (SCFM @ 100 psi).....	9
Pilot pressure (psi) minimum.....	40
Temperature.....	32° to 180° F
Working pressure.....	0 to 150
Response time (milliseconds).....	10

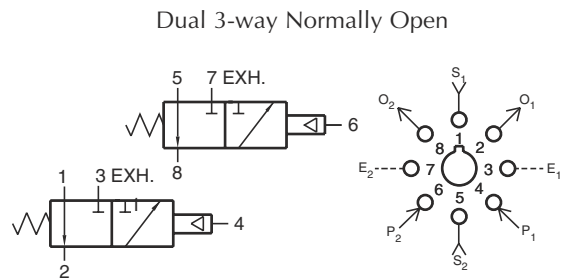

**Description:**

R-355 is a dual element combination of 2 independent, spring-return, 3-way valves in a single manifold, set-up for normally-OPEN usage only. Ports 3 and 7 are exhausts to atmosphere and can not be restricted.